

Substantiation of expedience of application of high-temperature utilization of used tires for liquefied methane production

S. Vambol ^a, V. Vambol ^{a,*}, O. Kondratenko ^a, V. Koloskov ^a, Y. Suchikova ^b

^a Technogenic and Ecological Safety Faculty, National University of Civil Protection of Ukraine, 61023, Chernyshevska str., 94, Kharkiv, Ukraine

^b Vocational Education Department, Berdyansk State Pedagogical University, 71100, Berdyansk, Shmidt str., 4, Ukraine

* Corresponding e-mail address: violavambol@gmail.com

ABSTRACT

Purpose: The purpose of this investigation is to substantiate by means of numerical simulation the expedience of high-temperature utilization of used tires with subsequent methanation of fuel gases and separation of multicomponent hydrocarbon mixtures to drain the liquefied methane.

Design/methodology/approach: The investigation was carried out by means of numerical simulation. In mathematical description of gas processes relations of thermodynamics and heat and mass transfer were used. To determine the coefficients of thermal and physical parameters of working bodies the Peng-Robinson equation of state was used through the computer program REFPROP. The system of equations is represented as the interrelations between the functional elements according to the principle "output from the element A – input into the element B". Its solution was obtained by the method of successive approximations, namely by the Newton-Raphson iteration method. Using this method we have determined the values of temperature, pressure, mass flow rate and mass content of the hydrocarbon gas mixture components in each reference cross-section of the power facility.

Findings: As a result of numerical simulation, it is determined that when the multicomponent hydrocarbon mixtures are separated, three flows of energy resources may be obtained: with a high mass content of methane of 91.5% and 83.4%, which may be used as motor fuel, and a gas flow suitable for maintaining the process of waste gasification. However, to remove heat in the condenser of the rectification column, it is necessary to use expensive liquid nitrogen. The cost of methane production may be reduced if the condenser is removed from the rectification column. However, such approach reduces the overall yield of commercial products almost in four times and significantly reduces the methane with the third product (molar percentage of 35%).

Research limitations/implications: The investigation was carried out for the material of used tires without a metal frame.

Practical implications: The implementation of the technology of high-temperature recycling of used tires gives the opportunity to use the generated synthetic gas to maintain the process of utilization, and gives the opportunity to produce liquefied methane, suitable for storage.

Originality/value: The main problem of high-temperature recycling of tires is the emission of toxic gas to the atmosphere. It is proposed to allocate methane energy resource from this gas. For the first time an attempt was made to justify the expedience of the technology of high-temperature utilization of tires for liquefied methane production.

Keywords: Ecology, Utilization, Tires, Numerical simulation, Multicomponent gas mixtures, Low-temperature separation

Reference to this paper should be given in the following way:

S. Vambol, V. Vambol, O. Kondratenko, V. Koloskov, Y. Suchikova, Substantiation of expedience of application of high-temperature utilization of used tires for liquefied methane production, Journal of Achievements in Materials and Manufacturing Engineering 87/2 (2018) 77-84.

CLEANER PRODUCTION AND BIOTECHNOLOGY

1. Introduction

The important task is management of surrounding environment in any sphere of human activity [1,2]. Increase of the number of automobiles and other vehicles on the roads of big industrial cities leads not only to the air pollution [3-5], but also to accumulation of the dangerous wastes – used tires [6]. Every year billions of tires are either located at the solid wastes landfills, used as fillers or burnt. Used tires storage at the wastes allocation landfills is not allowed due to their toxicity. Combustion of tires pollutes air with emission of carbon monoxide, sulphur dioxide, nitrogen oxides, organic pollutants and polyaromatic hydrocarbons. These gases favour appearance of chronic diseases such as skin eruption, eye irritation and breath problems. Due to increase of tires accumulation amounts the number of landfills raises. It both worsens sanitary condition of local settlements [7,8] and leads to unreasonable materials usage. Necessity to implement reliable and safe ways of waste utilization and detoxification arises [9]. For example, biodiesel production from wastes [10], creation of biocomposites filled with wastes [11], reliable and durable materials [12] or biodegradable materials [13].

Vegetable and food wastes may be utilized by composting with special mineral additives [14,15], by means of decomposition in biogas equipment installations with subsequent thermal treatment of fermented residue in pyrolysis furnace [16]. However, for automobile tires such ways of utilization are technologically and economically inexpedient. Thus necessity arises for mathematical substantiation of the process of environmentally safe utilization of used tires by means of high-temperature treatment.

Combustion of wastes, and used tires in particular, contradicts the principles of international legislation. The precaution principle is set in multiple international

regulations such as: the Convention for the Protection of the Marine Environment of the North-East Atlantic (OSPAR); the Convention on Long-Range Transboundary Air Pollution (LRTAP); The Basel Convention on the Control of Transboundary Movements of Hazardous Wastes and Their Disposal; the Bamako Convention on the Ban on the Import into Africa and the Control of Transboundary Movement and Management of Hazardous Wastes within Africa; the Stockholm Convention on Persistent Organic Pollutants; The Rio Declaration on Environment and Development. As the waste combustion is the process followed with the emission of unknown by-products, many of them bring harm to health of people. Therefore, the precaution principle demands to avoid such way of utilization. As it may be seen, the traditional waste utilization processes has exhausted their environmental and technological possibilities. Taking into account intensive growth of wastes accumulation, we may conclude that focus on them leads into deadlock. Increasing dynamics of natural surrounding pollution brought the world community to the fact that the safety system has to be directed not on the source but on the protection of humans and their surrounding environment. Such statement of a question is determined with modern concept of sustainable development. In such statement the environmental safety provision has to be done by system methods taking into account not only environmental and engineering factors but also economic and social conditions.

Such concept leads to the search of technologies of the used tires reuse as a fuel in modern processes of the thermal transformation. Gaseous products mainly consist of hydrogen, light hydrocarbons and carbon oxide. These gases may generate power to resolve the problem of tires accumulation [17]. For wastes utilization they often use high-temperature methods providing full decomposition of the waste materials into simple substances. The most simple installations are based on wastes pyrolysis processes

with subsequent usage of produced power or synthetic gas for heat or electrical power generation. Efficiency of such approach is investigated in work [18], but the problem of the most high-calorie fuel raw materials is still topical.

Experimental investigations of the scientists have shown that waste utilization plasma technology application provides synthetic gas with calorie characteristics higher than those at traditional technology usage [19]. In another work [20] the scientists have obtained parameters of steam gasification in demonstration reactor generating maximum amount of synthetic gas. However the methane content in it is insufficient to obtain fuel product satisfying requirements of normative acts on automobile fuelling. Therefore according to technology [21] it is proposed to enrich synthetic gas with methane in methanation reactor. Investigations in work [22] have shown advantages of such approach, description of the processes in developed for experimental investigations methanator is represented in work [23]. After enrichment it is proposed to provide low-temperature separation of the obtained multicomponent gas mixture for drainage of liquefied methane, liquefied methane-containing gas and fuel gas for heating, electrical power generation and gasification process maintaining.

The aim of investigation is to substantiate by means of numerical simulation the expedience of high-temperature utilization of used automobile tires with following methanation of outlet gases and separation of multicomponent hydrocarbon mixtures for liquefied methane release.

To reach this aim the following tasks were stated and resolved:

- to make the analysis of modern ways and technologies of dangerous wastes treatment and the determination of the most perspective directions of it;
- with the numerical simulation to substantiate opportunity of implementation of the low-temperature separation of multicomponent hydrocarbon mixtures;
- to determine the opportunity of optimization of the low-temperature separation of multicomponent hydrocarbon mixtures.

2. Materials and methods of investigations

The represented work is a part of scientific investigation for creation of economically efficient technological process of waste utilization. Origin of investigation is given in works [22,24], where the basic scheme of energy-technological facility for low-temperature separation of the gas mixture with increased

methane content is shown, technique of the complex energy-technological schemes calculation is proposed, initial parameters and assumptions are described:

- 1) value of recuperation lack in heat exchangers and the flows temperature difference at the pinch-point (minimal) $\Delta T_{\min} = 5$ K;
- 2) surrounding environment temperature $T_{s.e.} = 298$ K.
- 3) isentropic efficiency rate of the gas-expansion machine $\eta_{GEM} = 60\%$;
- 4) isentropic efficiency rate of the pump $\eta_p = 75\%$.
- 5) isentropic efficiency rate of the compressor $\eta_c = 75\%$;
- 6) value of hydraulic losses in elements of the low-temperature gas separation block is equal to zero;
- 7) heat exchange of functional elements of the scheme and connecting pipelines with surrounding environment is neglected.

For reliable calculation of low-temperature separation unit the mathematical models were developed for such functional elements: expansion turbine, recuperative heat exchanger, air cooling heat exchanger, pump, compressor, separator, rectification column. Additional elements (flow separator and mixer) were included to provide opportunity of complex schemes implementation.

Complexity of the processes taking place in rectification column do not allow creation of both detailed and relatively simple mathematical model for rectification column calculation. Thus, we use black box model to describe rectification column functioning. We set multicomponent flow in the inlet of rectification column with the known temperature T_{RC_IN} , pressure P_{RC_IN} and consumption G_{IN} . With known composition of the flow the set of subprograms designed for calculation of coefficients of heat-physical characteristics of working bodies allows to obtain mass and molar composition of steam and liquid phases of the flow supplied in the inlet of rectification column together with specific enthalpy of the inlet multicomponent two-phase flow.

For mathematical model of rectification column we have used following assumptions [25,26]:

- the value of hydraulic losses in rectification column is taken to be equal to zero;
- the heat exchange between structural elements of rectification column (plate section, reboiler and condenser) is neglected;
- the pressure inside the column cube is taken to be higher than the one inside the condenser;
- the value of the rectification column feed pressure is taken to be in between of the values mentioned above;
- the adjustment of the component composition of the products is made both by heat supply in reboiler and heat removal in condenser.

To enrich synthetic gas with methane the process was accomplished in presence of water steam and catalyser. After special activation the open-hearth slag was used as catalyser with 40 % efficiency. Reaction temperature is equal to 300°C. In methanator outlet we have obtained the gas mixture with following composition: CH₄ – 34.77%,

H₂ – 1.44%, CO – 25.55%, N₂ – 5.11%, water steam – 33.13%. Next the drainage is made to remove water steam from gas mixture (Table 1). Obtained multicomponent hydrocarbon mixture has to be processed with low-temperature separation to produce fuel raw materials suitable for storage.

Table 1.
Percentage content of the gas mixture components

Gas mixture component	Before methanation	After methanation	After water steam removal
CH ₄	6.54%	34.77%	52.00%
H ₂	56.36%	1.44%	2.15%
CO	28.24%	25.55%	38.21%
N ₂	3.41%	5.11%	7.65%
CO ₂	5.45%	0.00%	0.00%
Water steam	0.00%	33.13%	

Since the numerical simulation is the most efficient and convenient way of analysis for complex processes in multicomponent gas mixtures, in represented investigation we have accomplished numerical experiment. For this purpose, we have used classical approach and generally accepted thermodynamics relations including the Peng-Robinson equation of state for description of coefficients of heat-physical characteristics of working bodies. Complexity of calculation of multicomponent systems (with three and more components) does not allow application of the state diagrams. So at simulation we have used the REFPROP program as a tool for calculation of heat-physical characteristics coefficients. To solve the system of non-linear equations the Newton-Raphson iteration method was used.

3. Results of investigation and their discussion

To close the system of equations for each functional element of energy-technological facility we need to set values for following parameters:

- pressure P_1 , temperature T_1 , consumption G_1 and mass content of gas mixture components in the separation facility inlet;
- surrounding temperature $T_{o.c.}$;
- pressure of the products 1, 2 and 3 P_{26} , P_{27} and P_{28} correspondingly;
- pressure in rectification column of low-temperature separation of gas mixture P_{17} , pressure drop in rectification column $\Delta P_{RC} = P_{19} - P_{18}$, and mass content rate of methane in the steam phase flow drained from the recondenser of rectification column;

- value of heat recuperation lack ΔT in heat-exchange devices.

By means of numerical simulation we have accomplished the analysis of functioning of energy-technological facility of separation of multicomponent hydrocarbon mixtures with the subsequent optimization of its parameters in order to improve its efficiency and decrease energy costs for waste gasification. According to results of calculations (see Tab. 2) three flows of energy resources may be obtained at separation of multicomponent hydrocarbon mixtures. The flows with high mass content of methane – 91.5% (cross-section 28, Tab. 2) and 83.4% (cross-section 27, Tab. 2) – are compressed products and may be used as motor fuel (analogue of compressed automobile natural gas). The gaseous flow (section 26, Tab. 2) is suitable for maintaining of wastes gasification process.

It is obvious that proposed scheme of the low-temperature separation of multicomponent hydrocarbon mixtures satisfies conditions of the task and shows opportunity of its implementation. This scheme may be used as the basic one. Yet the more efficient alternative may be found.

For example, in the condenser of rectification column K-1 we suppose to use the refrigerant with the temperature less than -182°C allowing to remove heat power of 2.836 kWt. Liquid nitrogen meets requirements on temperature level. At normal conditions the value of hidden evaporation heat is equal to $\Psi = 197.6 \text{ kJ}/(\text{kg}\cdot\text{K})$, then refrigerant consumption is equal to 51.7 kg/h. We may exclude liquid nitrogen usage and decrease costs value if condenser is not included in the composition of the column. However, in such case, as it may be proven with the numerical simulation results (see Tab. 3), there will be no opportunity to separate the whole amount of methane from the “top” flow. The scheme of such alternative of the low-temperature gas separation facility is shown at the Figure 1.

Table 2.

Mass concentrations of hydrocarbon gas mixture components in reference sections*

No. of cross-section	Pressure, MPa	Temperature, °C	Consumption, kg/hour	Mass concentration of product			
				CH ₄	H ₂	CO	N ₂
1	0.1	30	60.0	0.3756	0.0196	0.4287	0.1761
2	0.1	30	54.0	0.3756	0.0196	0.4287	0.1761
...							
26	0.115	11.00	35.04	0.0023	0.0335	0.6782	0.2860
27	22.0	17.16	4.79	0.8348	0	0.1228	0.0424
28	22.0	-3.17	20.17	0.9153	0	0.0679	0.0168

*Due to limited amount of the article, we have shown parameters of energy-technological facility and mass content of product only for starting and finishing cross-sections.

Table 3.

Mass concentrations of hydrocarbon gas mixture components in reference sections for the scheme without recondenser*

No. of cross-section	Pressure, MPa	Temperature, °C	Consumption, kg/h	Mass concentration of product			
				CH ₄	H ₂	CO	N ₂
1	0.1	30	67.8	0.3756	0.0196	0.4287	0.1761
2	0.1	30	64.41	0.3756	0.0196	0.4287	0.1761
...							
26	0.115	23	59.8	0.3030	0.0222	0.4780	0.1968
27	22.0	20	4.09	0.8398	0	0.1190	0.0412
28	22.0	20	3.912	0.9998	0	0.0002	0

*Due to limited amount of the article, we have shown parameters of energy-technological facility and mass content of product only for starting and finishing cross-sections.

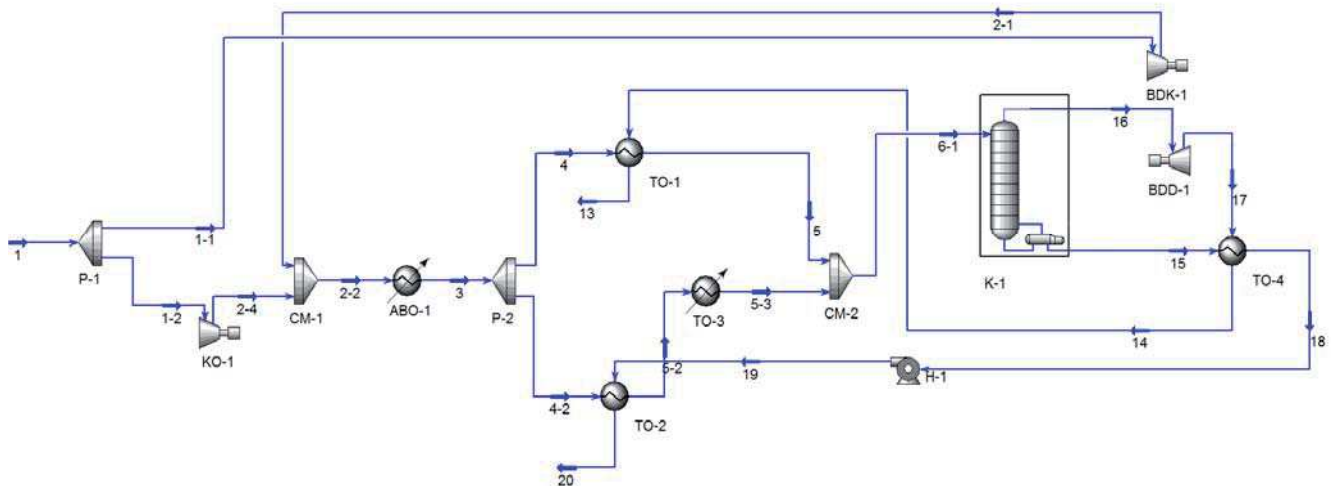

Fig. 1. The scheme of the low-temperature gas separation installation with rectification column without condenser

Amount of products obtained by the facility is equal to 5.242 kg/h of the product 1 with methane content of 99.98% and 54.76 kg/h of the product 2 with low content of methane. At implementation of the scheme shown at Figure 1 we have insignificant yield of pure methane in compressed shape.

It is also possible to provide raise of pure methane yield by means of increasing of pressure of mixture compression in compressor KO-1. However such improvement leads to organizational problems connected with the safety of objects functioning under high pressure.

4. Conclusions

1. We have identified that waste pyrolysis with production of power or synthetic gas is the most suitable for heat and electrical energy generation. Using the method of step-by-step approximation (the Newton-Raphson iteration method) in each reference cross-section of energy-technological facility we have determined values of temperature, pressure, mass consumption of the flow and mass concentrations of hydrocarbon gas mixture components.
2. The results of numerical simulations have shown that implementation of the facility of low-temperature separation of multicomponent hydrocarbon mixtures provides formation of flows of energy resources. The flows with high mass content of methane – 91.5% (cross-section 28, Tab. 2) and 83.4% (cross-section 27, Tab. 2) – are compressed products and may be used as motor fuel. The gaseous flow (section 26, Tab. 2) is fuel gas suitable for maintaining of used tires gasification process.
3. Renunciation to use refluxer (condenser) in rectification column decreases total marketable products yield almost in four times and methane loss with product 3 (molar percentage of 35%).

Acknowledgements

The authors' team is grateful to the management of the the National University of Civil Defense of Ukraine and Berdyansk State Pedagogical University for the opportunity to conduct scientific research in the field of recycling of waste materials.

Additional information

The work was carried out within the framework of scientific studies on the subjects of the Technogenic and Ecological Safety Faculty of National University of Civil Protection of Ukraine.

References

- [1] A. Kania, M. Roszak, M. Spilka, Evaluation of FMEA methods used in the environmental management, *Archives of Materials Science* 65/1 (2014) 37-44.
- [2] S. Vambol, V. Vambol, O. Kondratenko, Y. Suchikova, O. Hurenko, Assessment of improvement of ecological safety of power plants by arranging the system of pollutant neutralization, *Eastern European Journal of Enterprise Technologies* 3/10(87) (2017) 63-73. doi: 10.15587/1729-4061.2017.102314.
- [3] O.M. Kondratenko, S.O. Vambol, O.P. Strokov, A.M. Avramenko, Mathematical model of the efficiency of diesel particulate matter filter, *Naukovyi Visnyk Natsionalnoho Hirnychoho Universytetu* 6/150 (2015) 55-61.
- [4] C.M. Balaceanu, G. Iordache, Assessment of the air pollution at the industrial stations in metropolitan area of Bucharest, *Technogenic and ecological safety* 3(1/2018) (2018) 8-15. doi: 10.5281/ZENODO.1182485.
- [5] M.M. Biliaiev, T.I. Rusakova, V.Ye. Kolesnik, A.V. Pavlichenko, The predicted level of atmospheric air pollution in the city area affected by highways, *Naukovyi Visnyk Natsionalnoho Hirnychoho Universytetu* 1 (2016) 90-97.
- [6] Correctly disposed of 10% of auto tires (in Ukrainian), Available from: <http://ecotown.com.ua/news/V-Ukrayini-pravylnu-utylizuyetsya-lyshe-10-avtomobilnykh-shyn/>.
- [7] S. Vambol, V. Vambol, I. Bogdanov, Y. Suchikova, N. Rashkevich, Research of the influence of decomposition of wastes of polymers with nano inclusions on the atmosphere, *Eastern-European Journal of Enterprise Technologies* 6/10(90) (2017) 57-64. doi: 10.15587/1729-4061.2017.118213.
- [8] A. Rafiee, J.M. Delgado-Saborit, E. Gordi, B. Quémerais, V.K. Moghadam, W. Lu, F. Hashemi, M. Hoseini, Use of urinary biomarkers to characterize occupational exposure to BTEX in healthcare waste autoclave operators, *Science of the Total Environment* 631 (2018) 857-865.
- [9] V.A. Biletska, N.Ye. Yatsechko, V.I. Demura, A. Pavlychenko, Application of natural sorbents for waste detoxication, *Naukovyi Visnyk Natsionalnoho Hirnychoho Universytetu* 6 (2014) 120-125.
- [10] L. Pomenić, Z. Jurac, The influence of methyl esters on viscosity of biodiesel from waste and rapeseed oil blends, *Archives of Materials Science and Engineering* 62/2 (2013) 73-77.
- [11] V.M. Shmandiy, V.V. Nikiforov, V.P. Alferov, E.V. Kharlamova, V.A. Pronin, Use of blue-green algae for biogas production, *Gigiena i Sanitariia* 6 (2010) 35-41.
- [12] A. Kucukdogan, S. Ozturk, M. Sutcu, Bio-composites based on polypropylene filled with waste of camellia sinensis, *Archives of Materials Science and Engineering* 79/1 (2016) 12-18.
- [13] S. Vambol, V. Vambol, Y. Suchikova, I. Bogdanov, O. Kondratenko, Investigation of the porous GaP

- layers' chemical composition and the quality of the tests carried out, *Journal of Achievements in Materials and Manufacturing Engineering* 86/2 (2018) 49-60.
- [14] L.A. Dobrzański, A. Hudecki, Structure, geometrical characteristics and properties of biodegradable micro- and polycaprolactone nanofibers, *Archives of Materials Science and Engineering* 70/1 (2014) 5-13.
- [15] G.V. Krusir, Acid-base and ionexchange properties of dietary fibers, *Prikladnaia Biokhimiia i Mikrobiologiia* 28/2 (1992) 297-303.
- [16] M.M. Maksimov, V.O. Davydov, G.V. Krusir, O.B. Maksimova, Increasing of process energy efficiency of biogas plants production processing, *Proceedings of Odessa Polytechnic University* 3/53 (2017) 43-53.
- [17] R. Kommineni, H. Boddapu, S. Thomas, Scope of Pyrolysis Process as a Sustainable Method to Dispose Waste Tires: a Review, in: N. Sharma, A.K. Agarwal, P. Eastwood, T. Gupta, A.P Singh (Eds.), *Air Pollution and Control*, Springer, 2018, 247-260, doi: 10.1007/978-981-10-7185-0_14.
- [18] E.B. Machin, D.T. Pedroso, J. Carvalho, Technical assessment of discarded tires gasification as alternative technology for electricity generation, *Waste Management* 68 (2017) 412-420, doi: 10.1016/j.wasman.2017.07.004.
- [19] B. Lemmens, H. Elslander, I. Vanderreydt, K. Peys, L. Diels, M. Oosterlinck, M. Joos, Assessment of plasma gasification of high caloric waste streams, *Waste Management* 27/11 (2007) 1562-1569, doi: 10.1016/j.wasman.2006.07.027.
- [20] Q. Zhang, L. Dor, W. Yang, W. Blasiak, Properties and optimizing of a plasma gasification & melting process of municipal solid waste, *Proceedings of the International Conference "Thermal Treatment Technology & Hazardous Waste Combustors" IT3/HWC*, 2010, 296-316.
- [21] V. Vambol, Numerical integration of the process of cooling gas formed by thermal recycling of waste, *Eastern European Journal of Enterprise Technologies* 6/8(84) (2016) 48-53, doi: 10.15587/1729-4061.2016.85455.
- [22] S.A. Vambol, Yu.V. Shakhov, I.I. Petukhov, V.V. Vambol, Mathematical model of calculation of the separator and the compressor unit of separation of gas mixtures in waste management, *Technology Audit and Production Reserves* 1/1(27) (2016) 50-53, doi: 10.15587/2312-8372.2016.5861.
- [23] Yu.V. Shakhov, I.I. Petukhov, V.V. Vambol, Mathematical model of energy-technological plants for the separation of multicomponent gas mixtures, *Visnik NTU «KhPI»: Matematichne modelyuvannya v tekhnitsi ta tekhnologiyakh* 41(1150) (2015) 134-139.
- [24] S. Vambol, Yu. Shakhov, I. Petukhov, V.A Vambol, Mathematical description of the separation of gas mixtures generated by the thermal utilization of waste, *Eastern European Journal of Enterprise Technologies* 1/2(79) (2016) 35-41, doi: 10.15587/1729-4061.2016.6048.
- [25] I.A. Aleksandrov, *Rektifikatsionnyye i absorbtionnyye apparaty*, Khimiya, Moscow, 1971, 296 (in Russian).
- [26] V.P. Isachenko, V.P. Osipova, A.S. Sukomel, *Teploperedacha*, Energoizdat, Moscow, 1981, 416 (in Russian).
- [27] Dzh. KH'yuit, L. Khol-Teylor, *Kol'tsevyye dvukhfaznyye techeniya*, Energiya, Moscow, 1974, 408 (in Russian).
- [28] D. Battervors, Dzh. Kh'yuit, *Teploperedacha v dvukhfaznom potoke*, Energiya, Moscow, 1980, 328 (in Russian).
- [29] *Relap5/MOD3 Cod Manual Nureg/CR-5535 (INEL - 95/0174)*. Vol. I-V. 1995. Idaho National Engineering Laboratory, Idaho Falls, Idaho.